

Note:
Please pre-fold along all creases before beginning the first step.

1

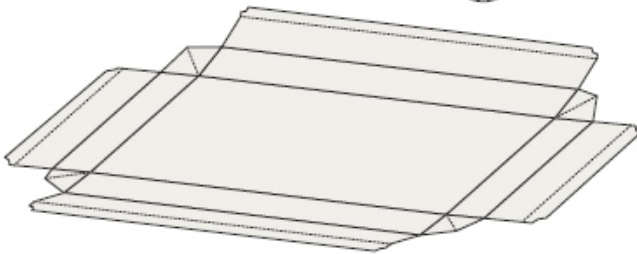

2

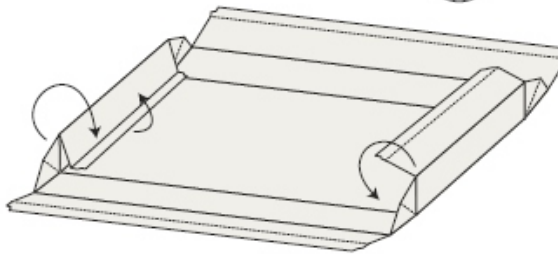

3

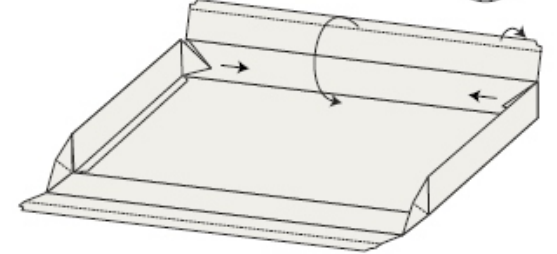

4

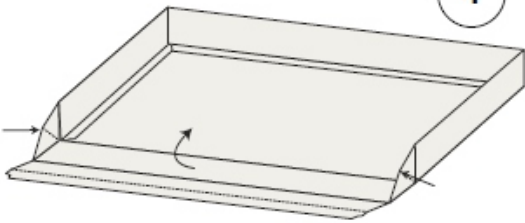

5

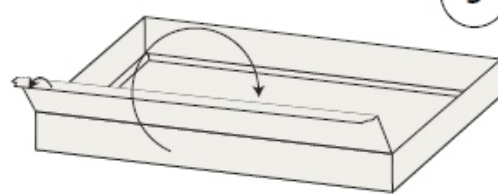

6

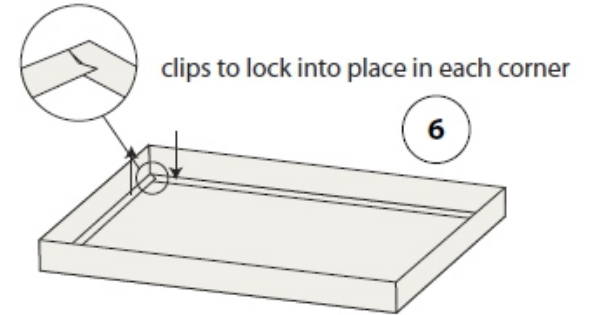

web corner (double crease) - clip locking feet